

Decoupling Capacitors

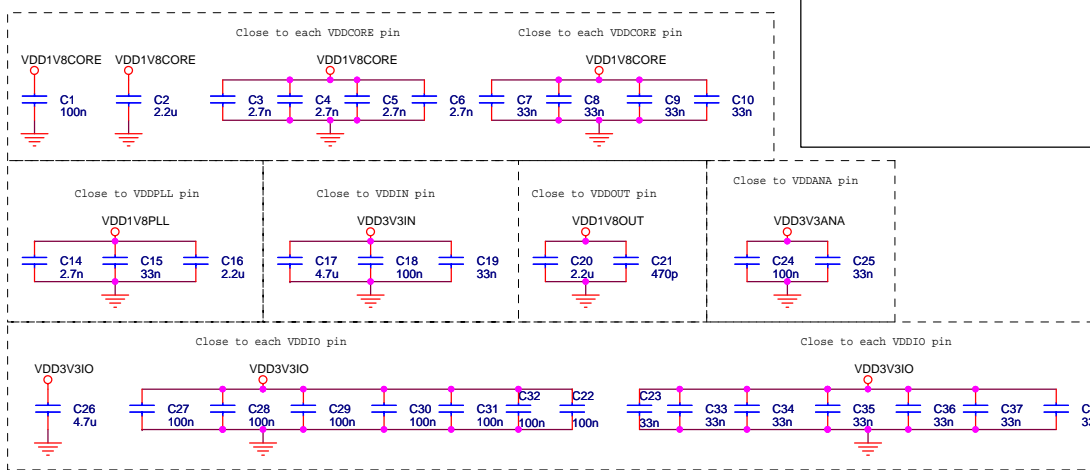

Clock Circuitry

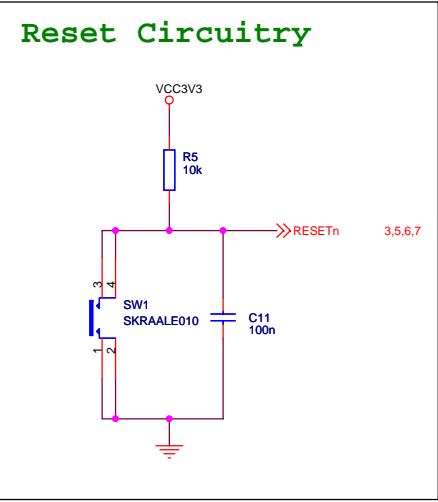
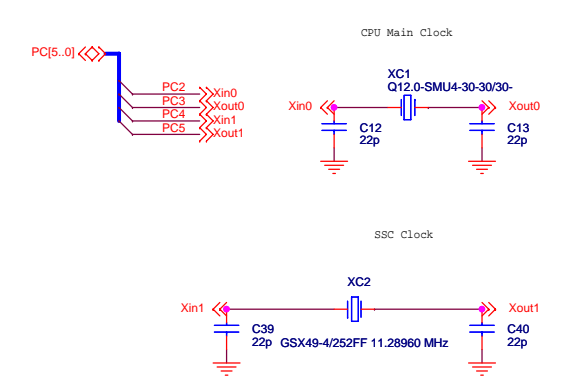

bom-HWREV10		
ATMEL Norway AS Vestre Rosten 79 N-7075 TILLER Norway		
Title	EVK1105	
Size	Document Number	Rev
A3	UC3A	B
Date:	Friday, June 27, 2008	Sheet 1 of 12

External Power Supply (DC +5V +/- 10%)
If applied, automatic USB power switch is disabled

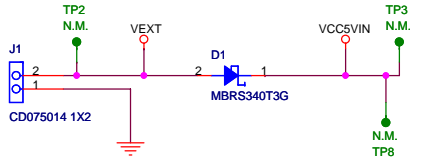

Automatic USB power switch
When external power supply is not provided, the board can be powered by VBUS_USER or VBUS_VPC (VBUS_VPC has the higher priority)
Current limiter value is 530 mA

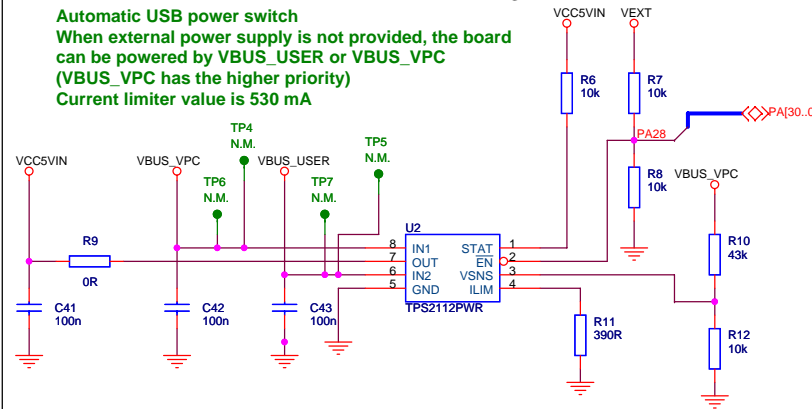

Boost converter for stable 5V supply. Output 5V, 1.5A.

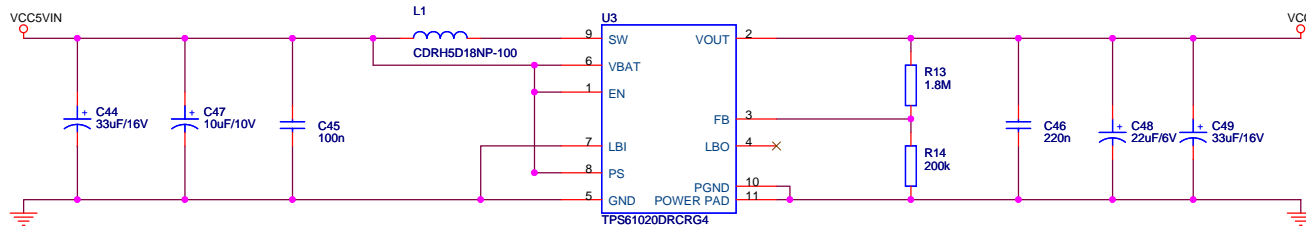

Test Point duplicated to allow one present on each side of the board

Buck Converter

Generates 3.3V from 5V.

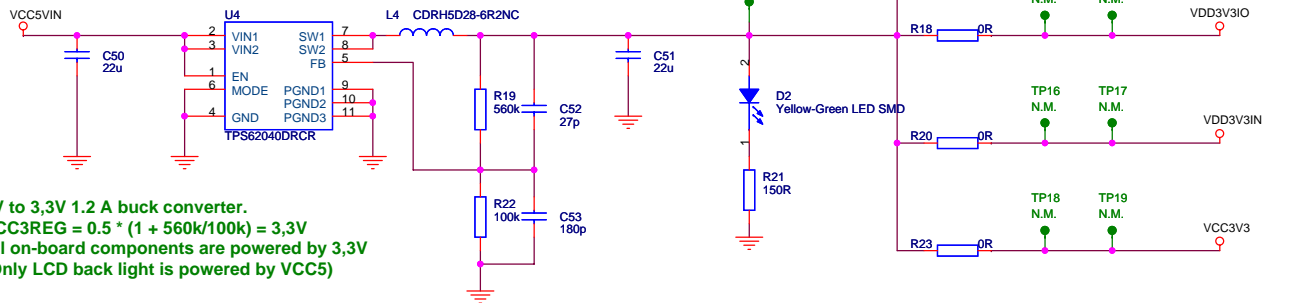

5V to 3.3V 1.2 A buck converter.
 $VCC3REG = 0.5 * (1 + 560k/100k) = 3.3V$
All on-board components are powered by 3.3V
(Only LCD back light is powered by VCC5)

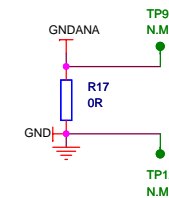

bom-HWREV10

ATMEL Norway AS
Vestre Rosten 79
N-7075 TILLER
Norway



Title	EVK1105		Rev	B
Size	A3	Document Number	Power supply	
Date:	Thursday, September 04, 2008		Sheet	2 of 12

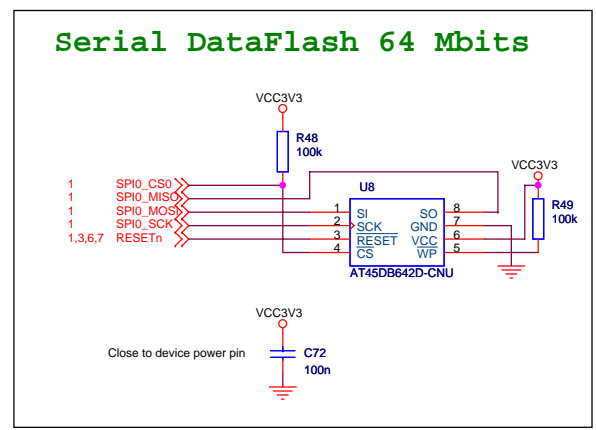
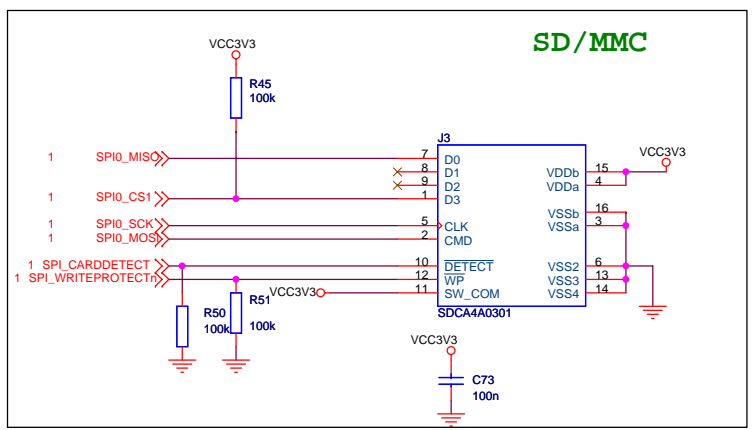
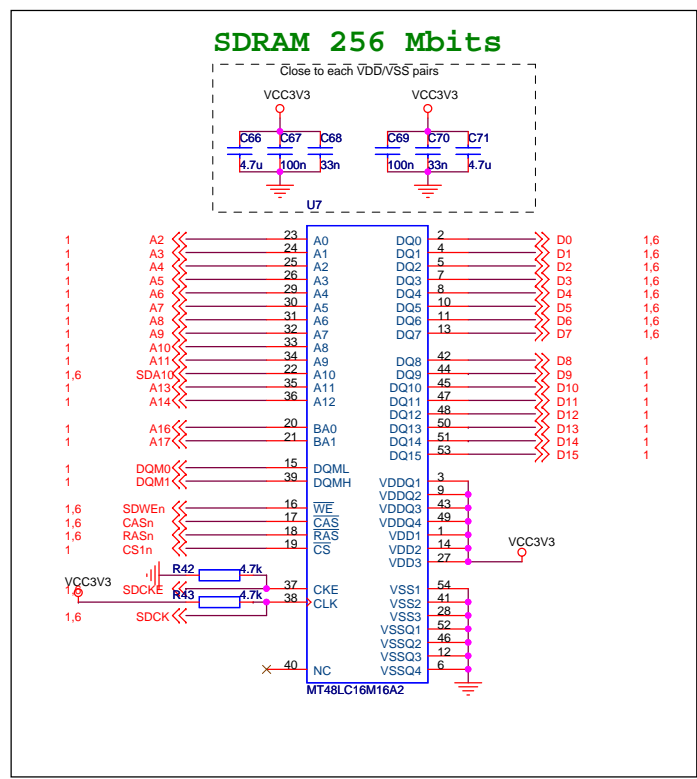
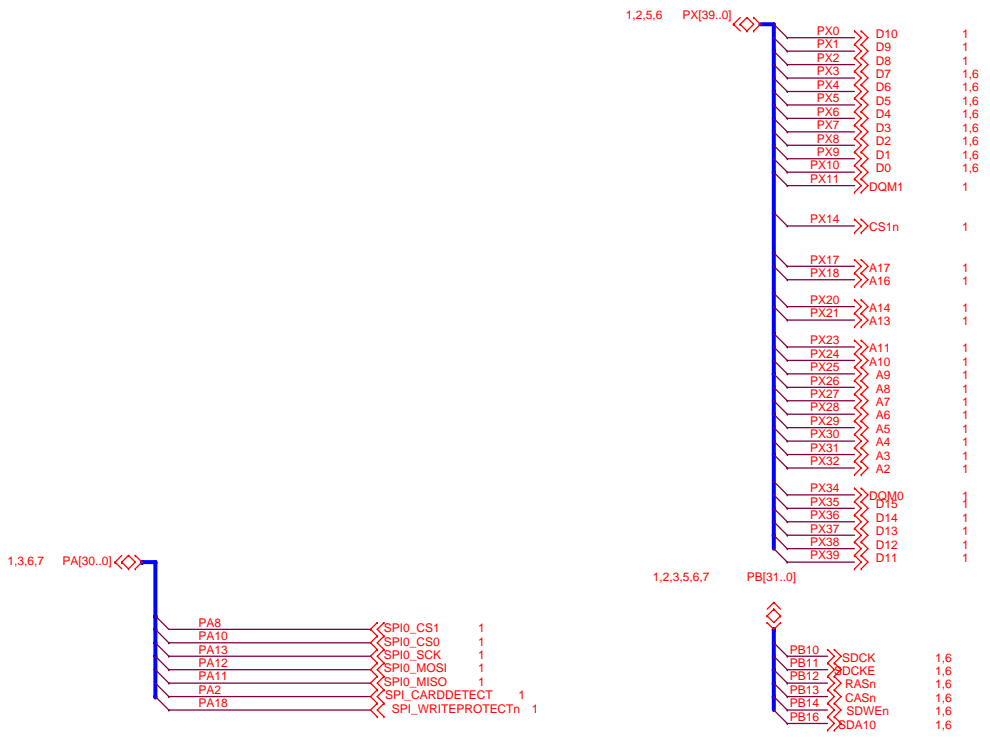

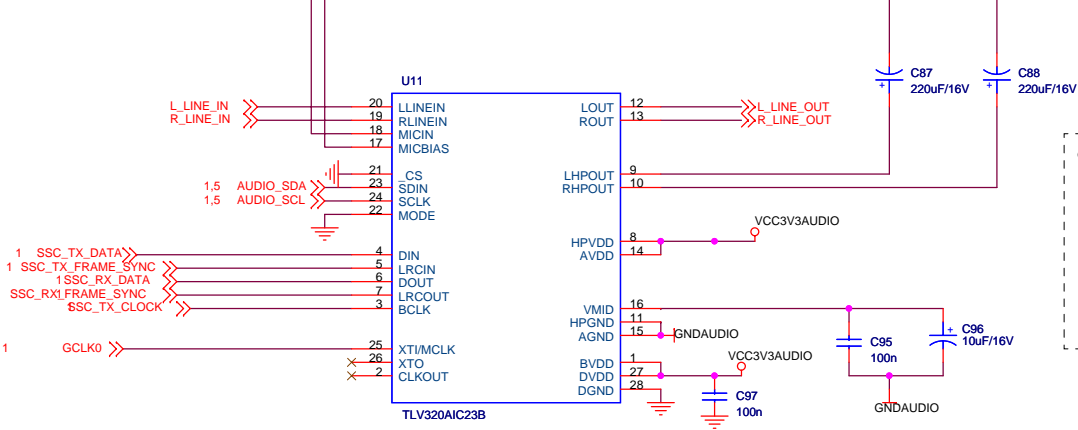
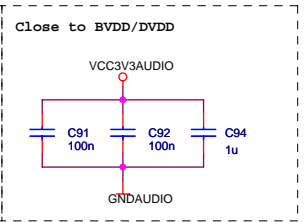
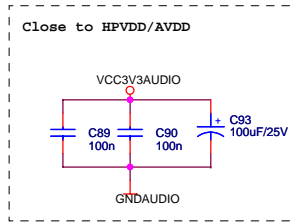
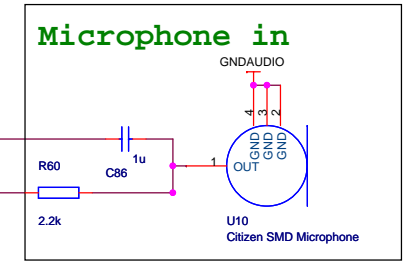
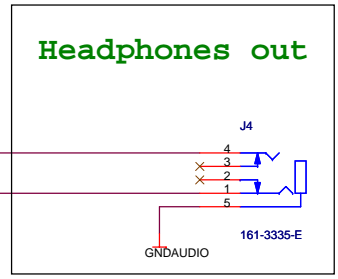
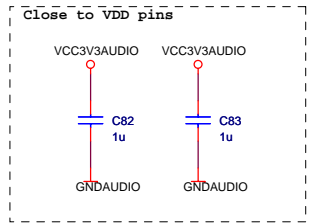
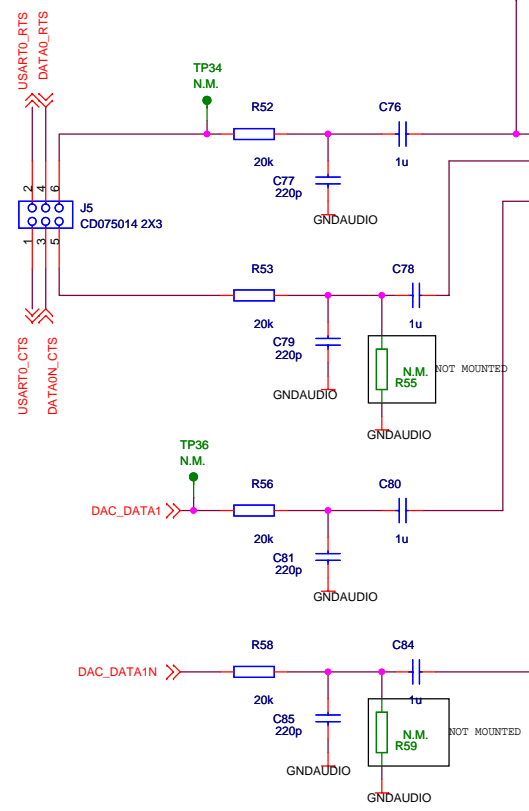
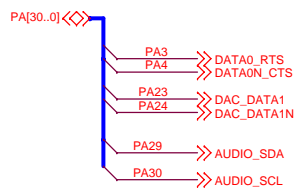
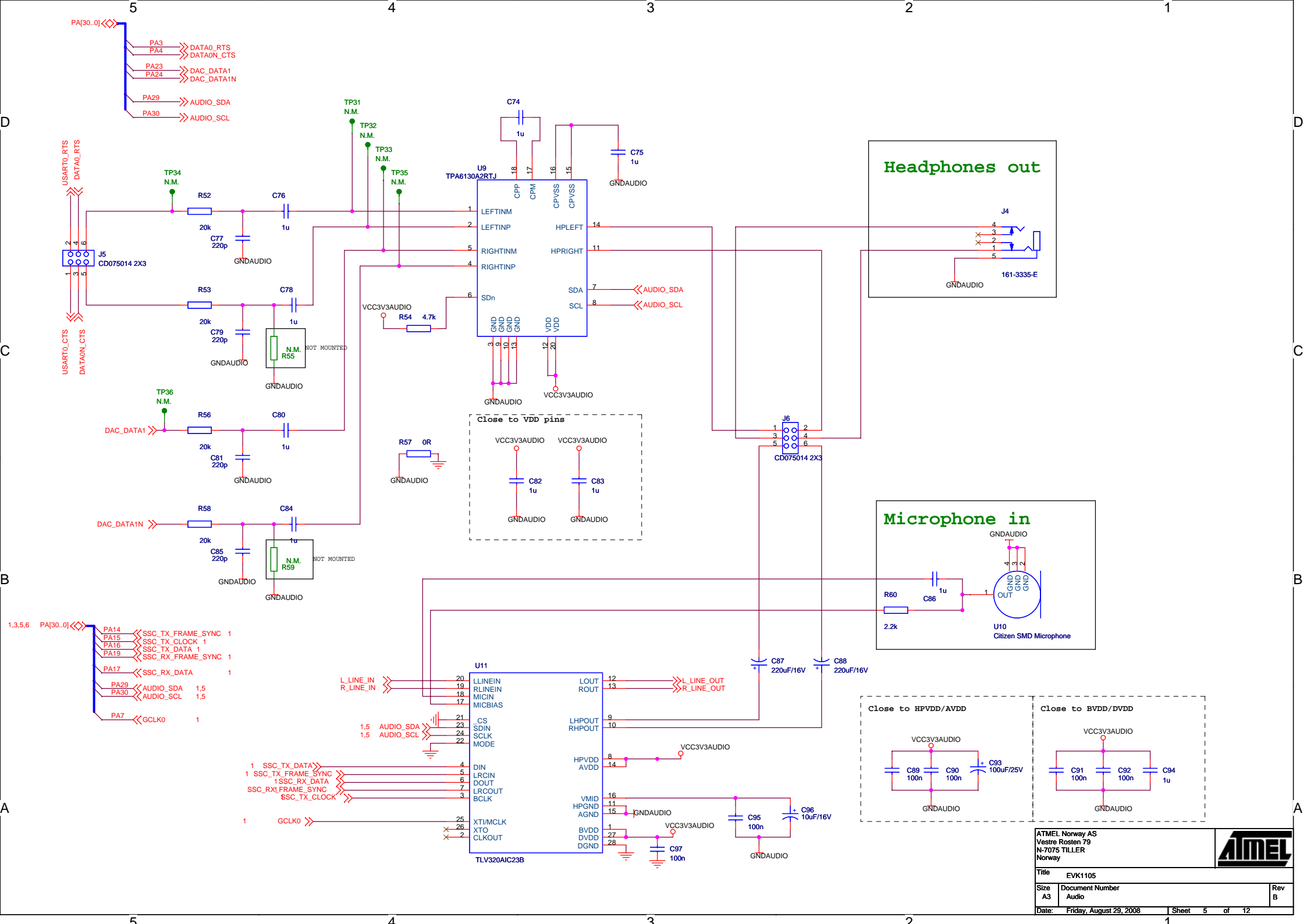

ATMEL Norway AS Vestre Rosten 79 N-7075 TILLER Norway		
Title	EVK1105	
Size	A3	Document Number
Date:	Friday, August 29, 2008	Audio
Sheet	5	Rev
of	12	B

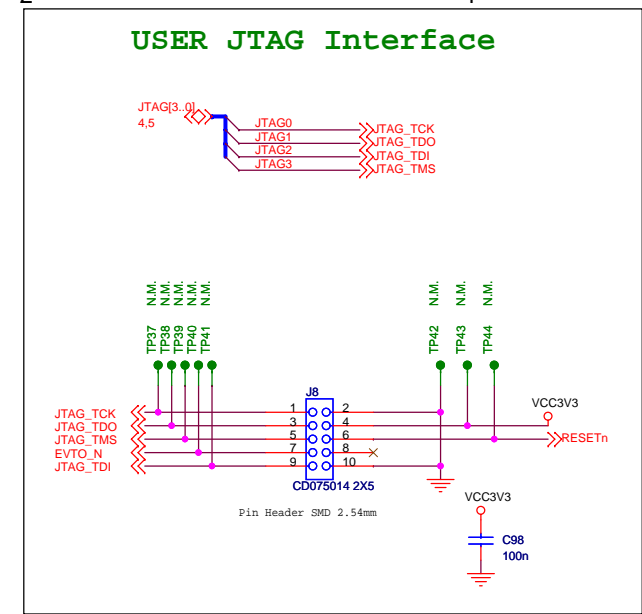
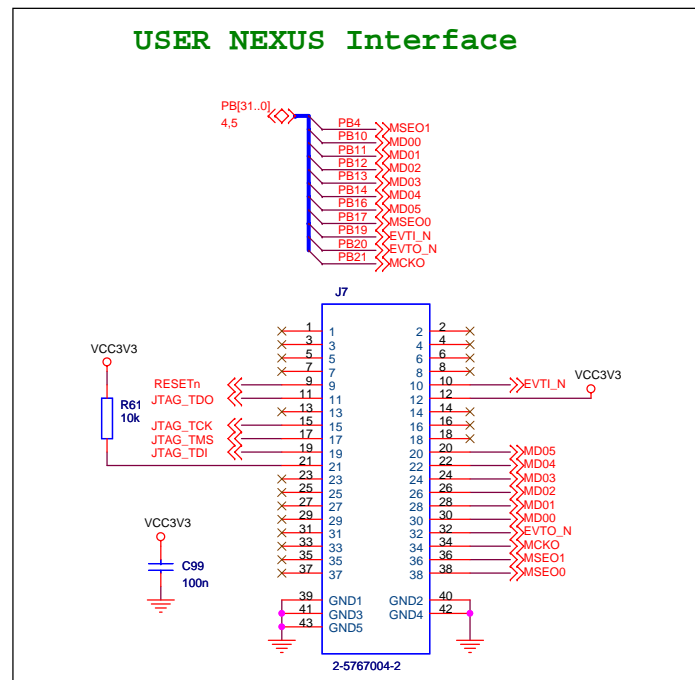

bom-HWREV10

ATMEL Norway AS
Vestre Rosten 79
N-7075 TILLER
Norway



Title		EVK1105	
Size	A3	Document Number	Debug connectors
Date:	Thursday, June 26, 2008	Sheet	6 of 12
Rev	B		

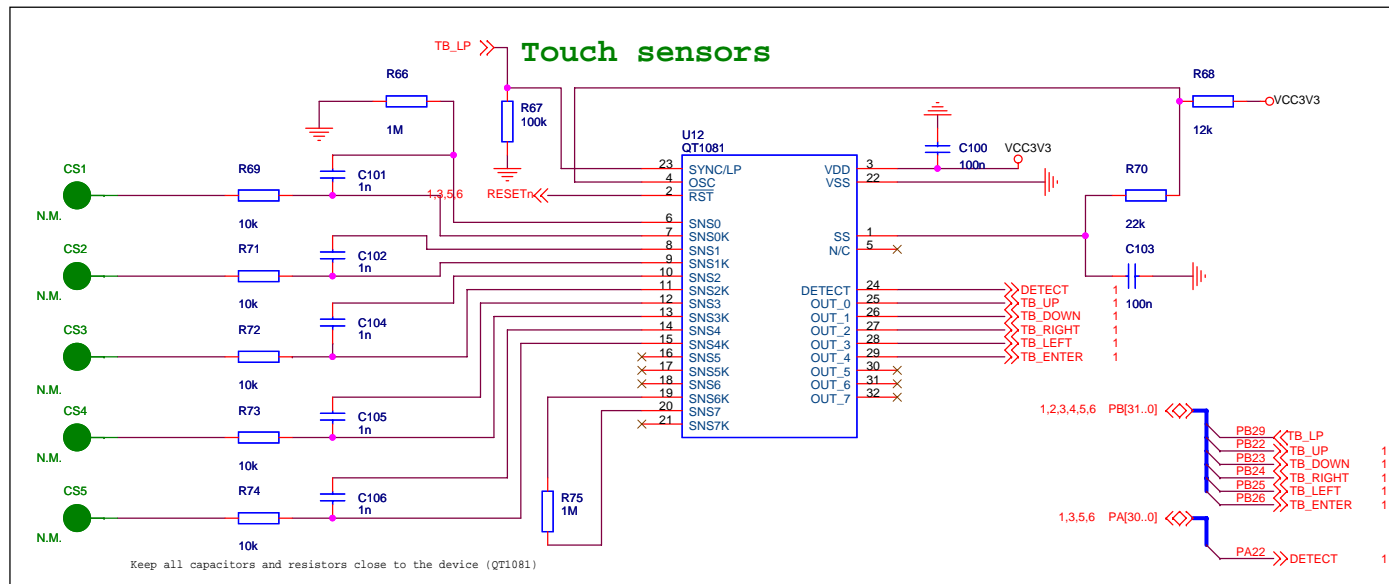
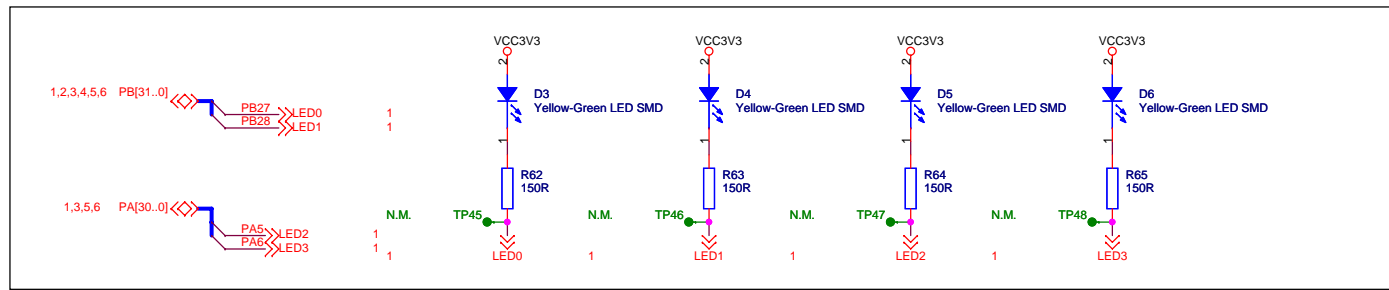

bom-HWREV10

ATMEL Norway AS
 Vestre Rosten 79
 N-7075 TILLER
 Norway



Title		EVK1105	
Size	Document Number	Rev	
A3	Sensors	B	
Date:	Thursday, June 26, 2008	Sheet	7 of 12

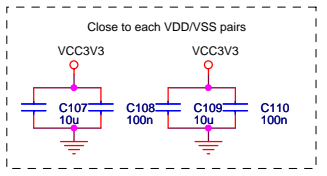
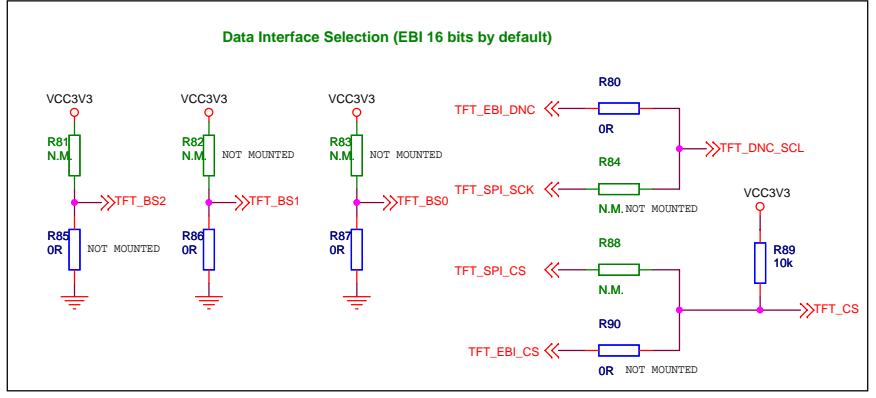
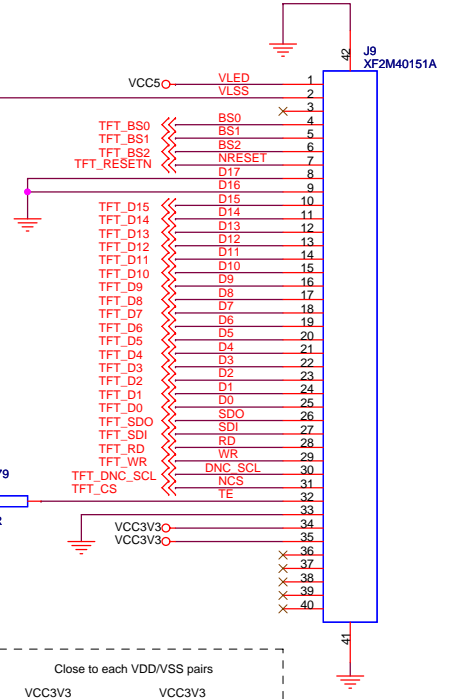
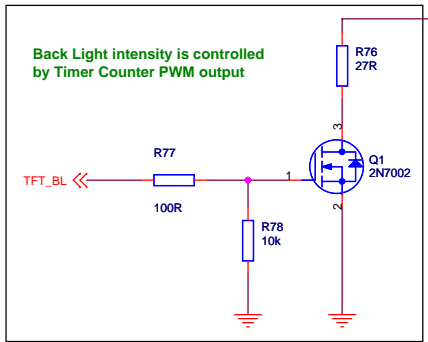
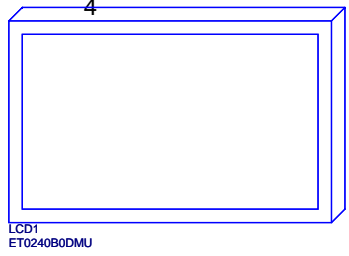
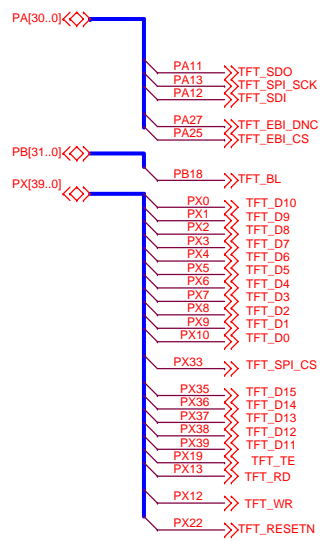

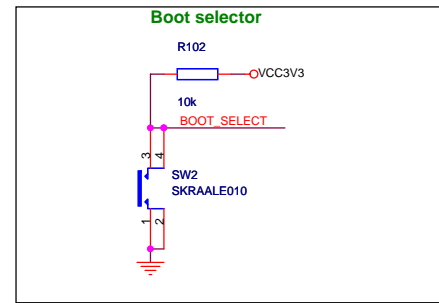
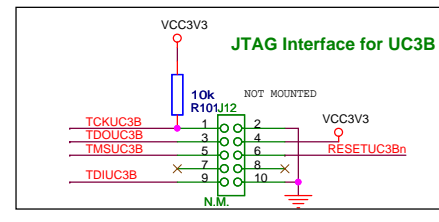
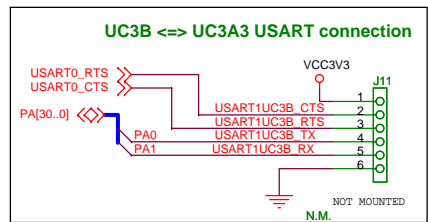
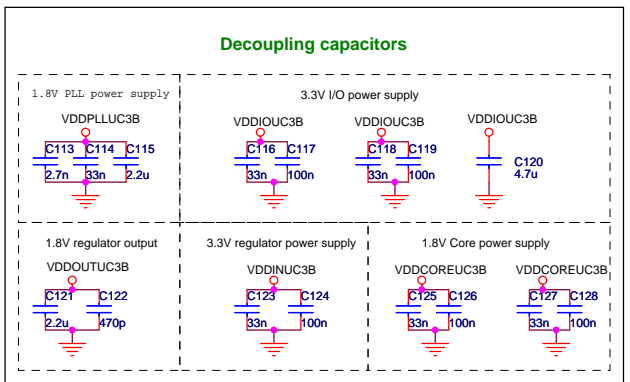
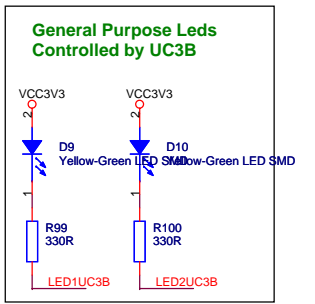
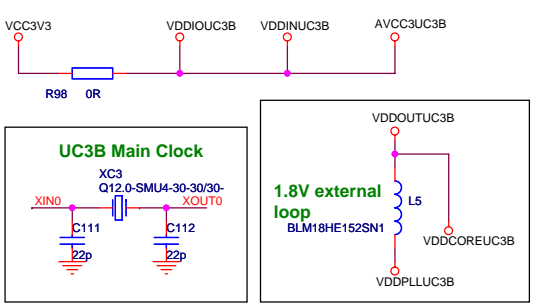
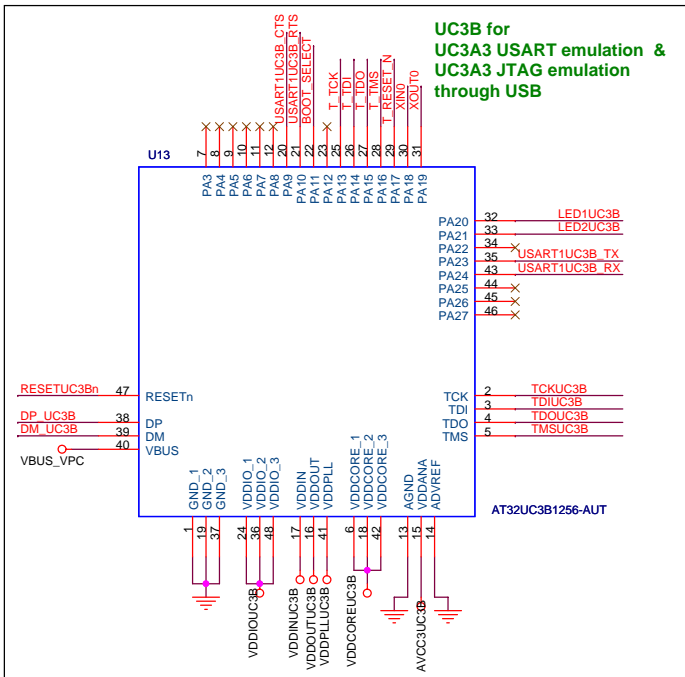
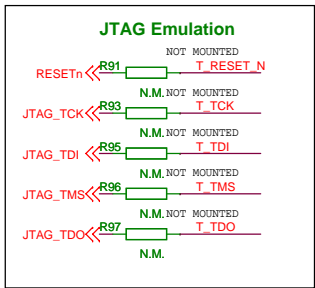
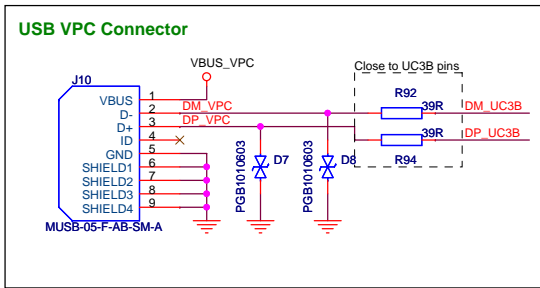

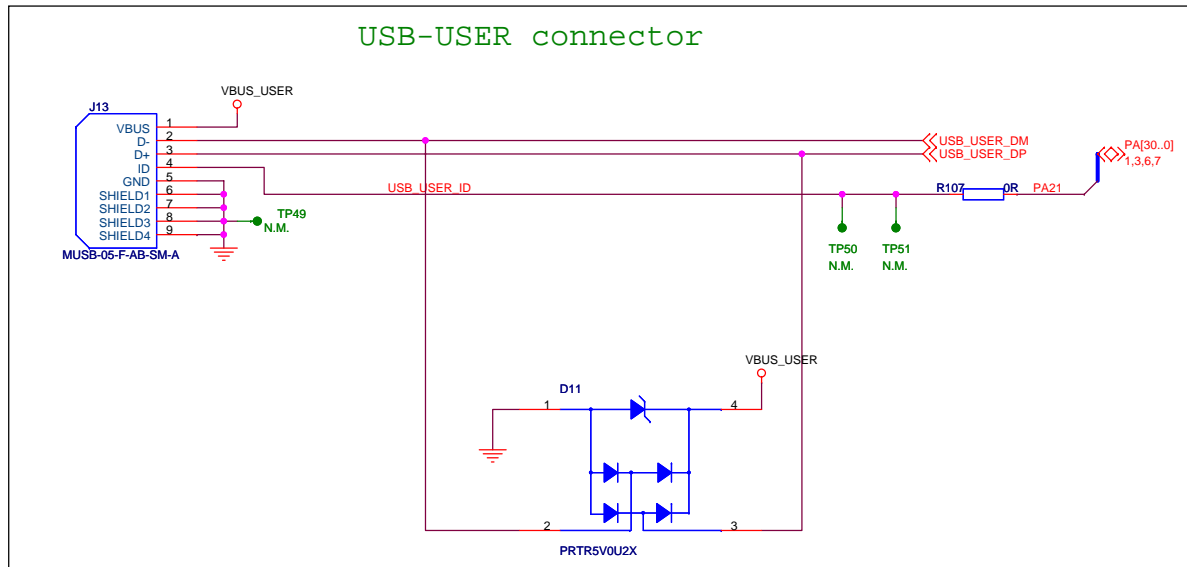
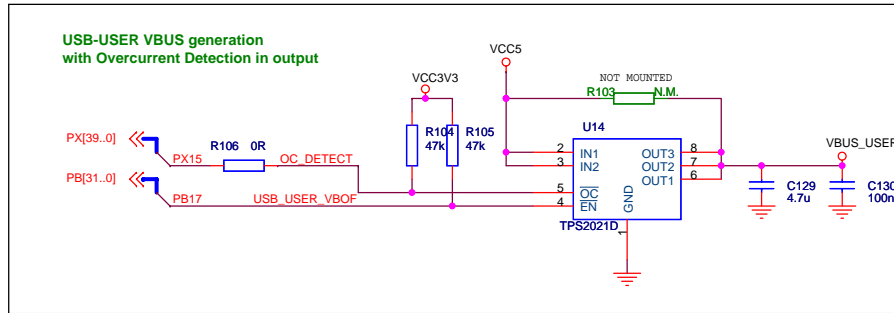

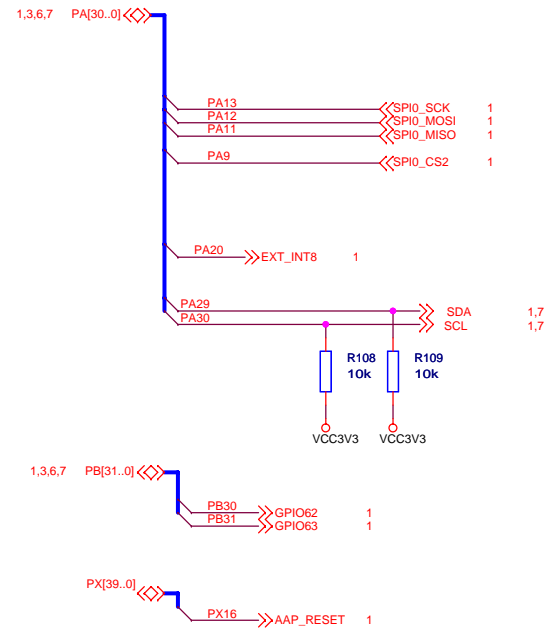

Alternative sound input/output

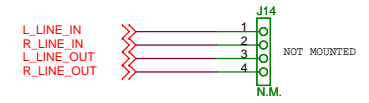

Expansion for AAP

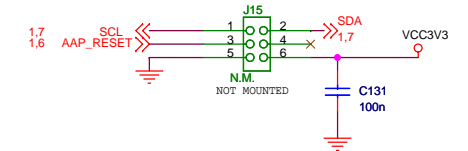

ZigBee extension

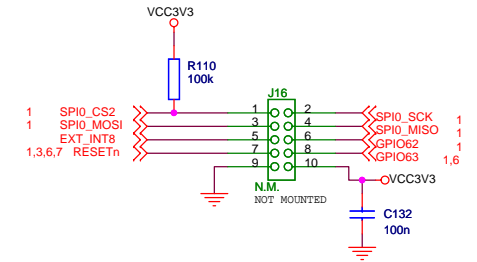

bom-HWREV10

ATMEL Norway AS
 Vestre Rosten 79
 N-7075 TILLER
 Norway



Title		EVK1105	
Size	Document Number	Rev	
A3	Extensions	B	
Date:	Thursday, June 26, 2008	Sheet	11 of 12

RevB created (LH)

